



SERIE VIBRATORI CON SCARICO AUTOMATICO

VAM



SERIE VAM	Diametro macchina	Larghezza vasca	Altezza vasca	Altezza macchina	Altezza scarico pezzi	CAPACITA'	MOTORE	PESO
	A	B	C	D	E			
	mm	mm	mm	mm	mm	dm3	kw	kg
30	667	159	159	805	458	30	0,75	150
75	921	227	227	902	459	60	0.75	220
150	1141	267	273	948	400	150	0,75	330

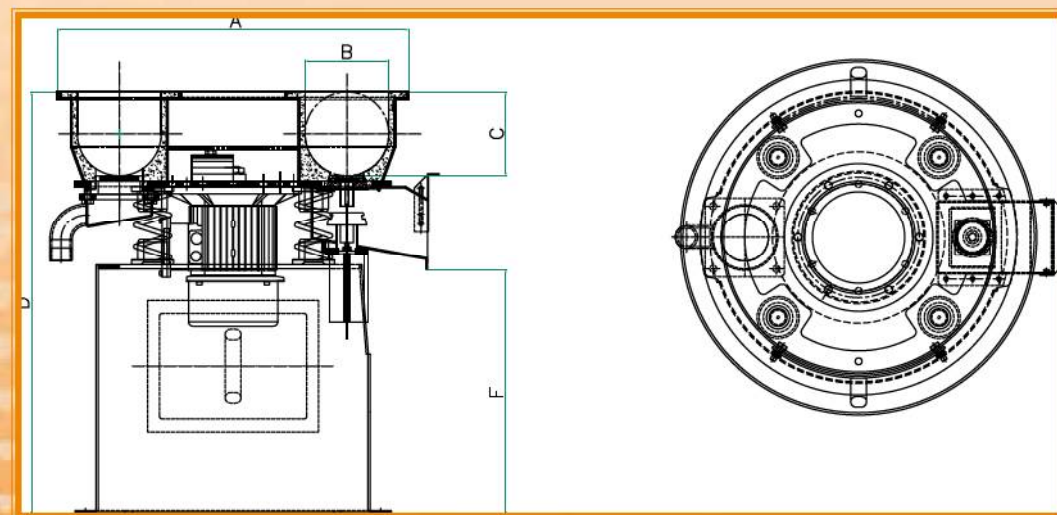



SERIE VIBRATORI CON SCARICOAUTOMATICO

VA



SERIE VA	Diametro macchina	Larghezza vasca	Altezza vasca	Altezza macchina	Altezza scarico pezzi	CAPACITA'	MOTORE	PESO
	A	B	C	D	E			
	mm	mm	mm	mm	mm	dm3	kw	kg
30	667	159	159	805	458	30	0,75	150
75	921	227	227	902	459	60	0,75	220
150	1141	267	273	948	400	150	0,75	330
300	1376	324	335	987	372	270	1,5	530
400	1560	355	358	1380	742	380	2,5	600
550	1775	406	383	1125	426	555	4,1	950
700	1978	460	459	1600	819	700	4,1	1100

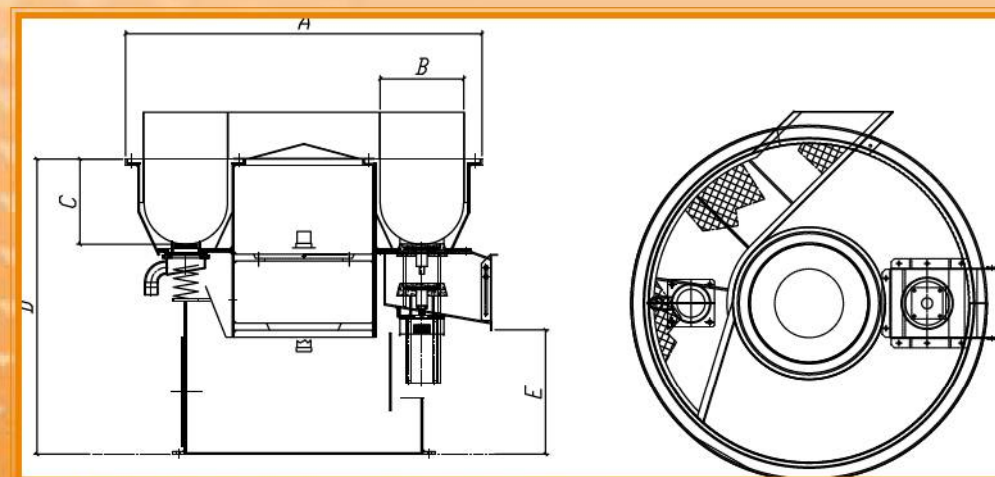



SERIE VIBRATORI CON SCARICO AUTOMATICO

VAO



SERIE VAO	Diametro macchina	Apertura vasca	Altezza vasca	Altezza macchina	CAPACITA'	MOTORE	PESO
	A	B	C	D			
	mm	mm	mm	mm	dm3	kw	kg
125	1348	150	231	909	135	2.15	430
250	1700	200	285	909	260	4.0	540
420	2000	250	335	1000	430	7.0	720
550	2200	280	365	1000	560	7.0	930

